

DOCUMENT No: 200-001-552

REVISION HISTORY					
REV	DESCRIPTION	REF. No.	DATE	DRWN BY:	CHK BY:
0	Initial Release	WO# 1348	2020-08-26	SA	JC

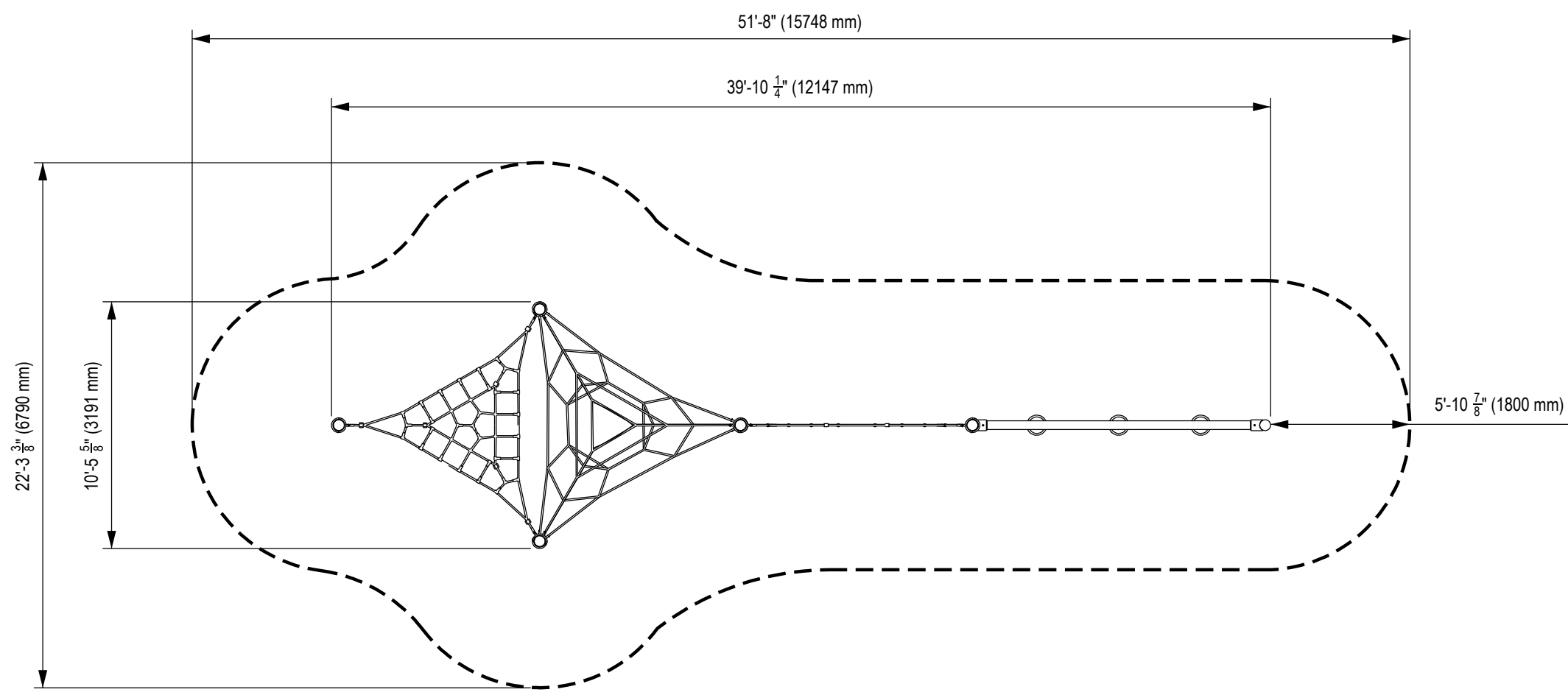

1
-
CSA USE ZONE - PLAN VIEW

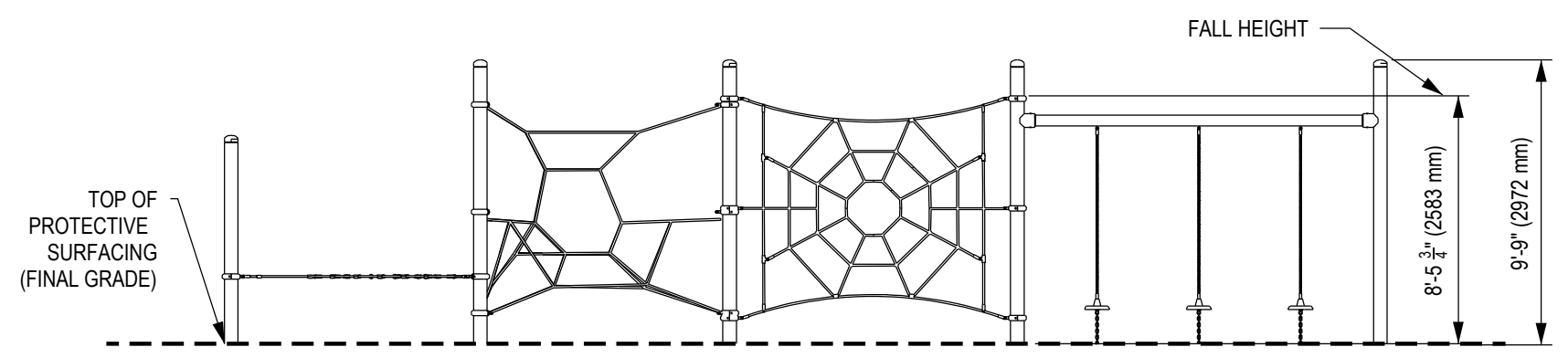

2
-
ELEVATION VIEW

ENGINEERING SEAL:

CLIENT: STOCK

PROJECT NAME: STOCK

PRODUCT NO: IM-1042

DRAWING TITLE:
**PLAYLAND MINI
CSA USE ZONE**

REV:	SHEET:	SHEET SIZE:	SCALE:
0	1 OF 1	PA3	NTS
DESIGNED BY:	S.ALKATHERI	DATE:	2021-08-26
DRAWN BY:	S.ALKATHERI	DATE:	2021-08-26
CHECKED BY:	J.CHEN	DATE:	2021-08-27
REVIEWED BY:		DATE:	
APPROVED BY:		DATE:	

DYNAMO
PLAYGROUNDS



Local: 613-446-0030
Toll free: 800-790-0034
Email: info@dynamoplaygrounds.com
Fax: 613-446-0034
URL: www.dynamoplaygrounds.com

REVISION HISTORY					
REV	DESCRIPTION	REF. No.	DATE	DRWN BY:	CHK BY:
0	Initial Release	WO# 1348	2020-08-26	SA	JC

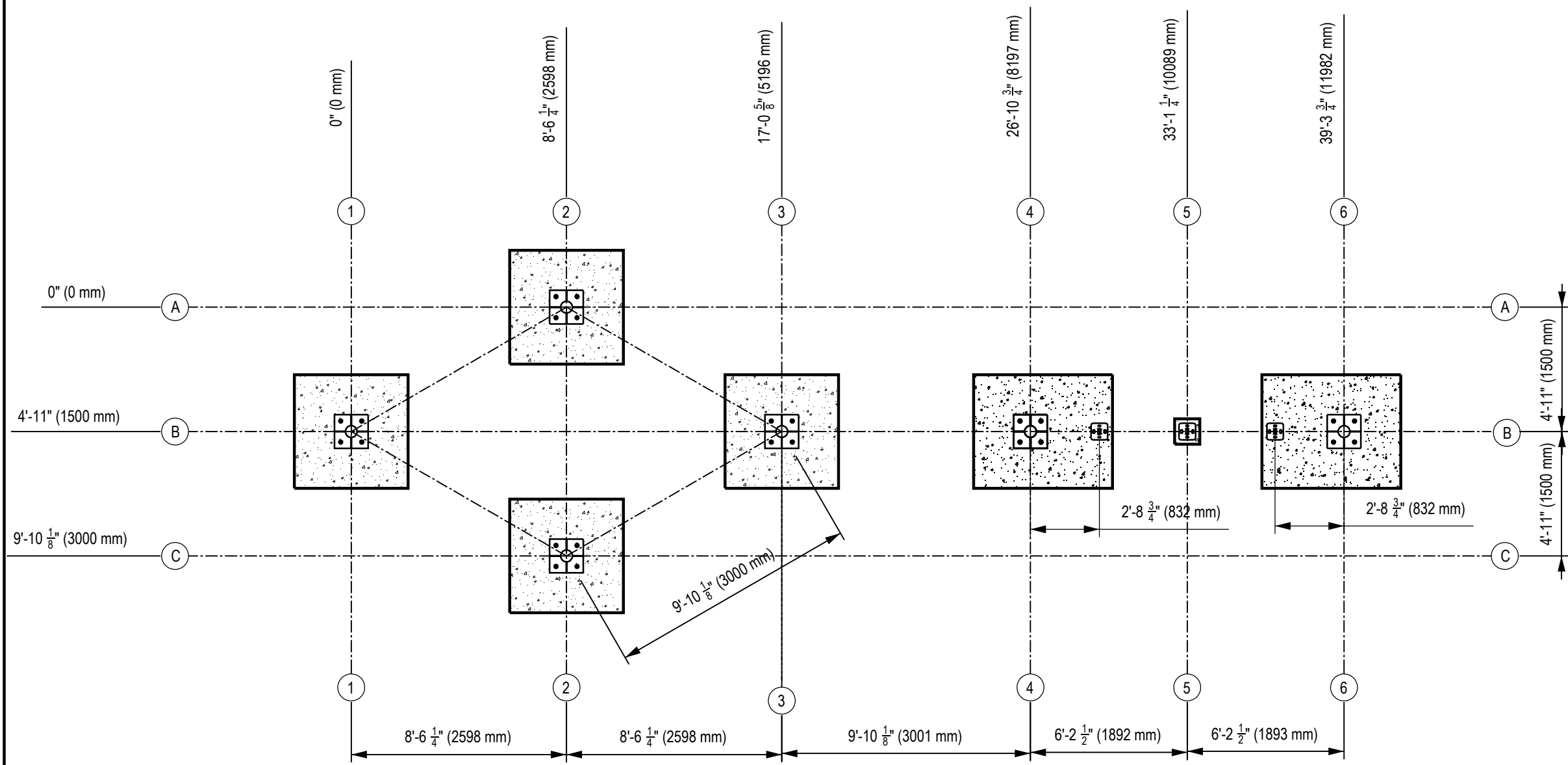

1 FOUNDATION LAYOUT PLAN VIEW

GENERAL NOTES:

1. THE FOUNDATION IN THE DRAWING TO BE USED AS A MINIMUM GUIDELINE. CHECK WITH LOCAL ENGINEERS. TO ENSURE MINIMUM REINFORCEMENT TO BE APPLIED.
2. THE CONCRETE SHALL BE GRADE C25 (CHARACTERISTIC STRENGTH OF 3500 PSI AT 28 DAYS) MINIMUM.
3. THE FOUNDATION SHALL BE PLACED ON FIRM, UNDISTURBED SOIL SURFACE. WHEREVER EXCAVATION OCCURS BELOW THE DESIGNED FOUNDATION LEVEL, WELL COMPACTED BACK FILL OR LEAN CONCRETE SHALL BE USED FOR LEVELING.
4. BACKFILLING FOR FOUNDATION SHALL BE PLACED EVENLY IN 6" (150mm) LAYERS. LAYERS SHALL BE WELL COMPACTED.
5. THE FOUNDATION DESIGN IS SUITABLE FOR SOIL WITH A BEARING CAPACITY OF 1600 PSF (80 KPA) AND ABOVE.
6. THE FOUNDATION DESIGN IS SUITABLE FOR SOIL WITH FROST LINE OF 4' (1200 MM) OR LESS.

ENGINEERING SEAL:

CLIENT:	STOCK
PROJECT NAME:	STOCK
PRODUCT NO:	IM-1042

DRAWING TITLE:
PLAYLAND MINI FOUNDATION DRAWING

REV:	SHEET:	SHEET SIZE:	SCALE:
0	1 OF 2	PA3	NTS

DESIGNED BY:	DATE:
DRAWN BY: S.ALKATHERI	DATE: 2021-08-26
CHECKED BY: J.CHEN	DATE: 2021-08-27
REVIEWED BY:	DATE:
APPROVED BY:	DATE:

DYNAMO
PLAYGROUNDS

Local: 613-446-0030
Toll free: 800-790-0034
Email: info@dynamoplaygrounds.com
Fax: 613-446-0034
URL: www.dynamoplaygrounds.com

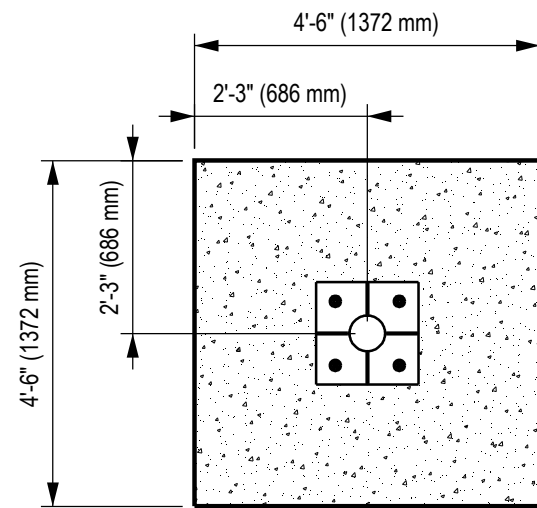

2 FT-1 DETAIL PLAN VIEW
2

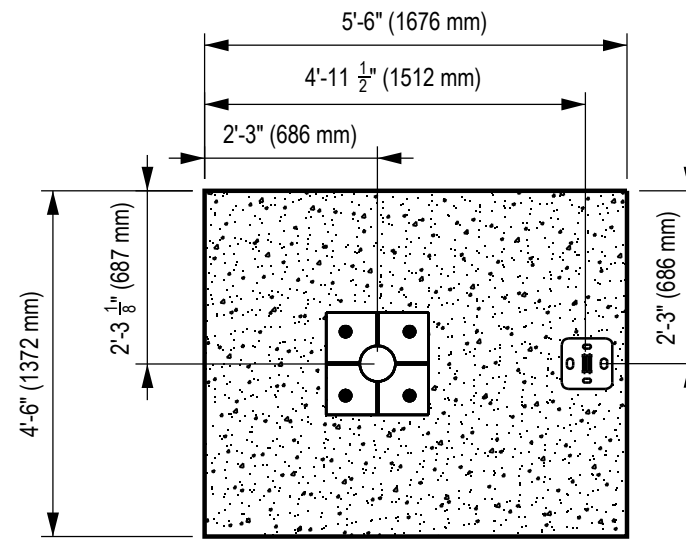

4 FT-2 DETAIL PLAN VIEW
2

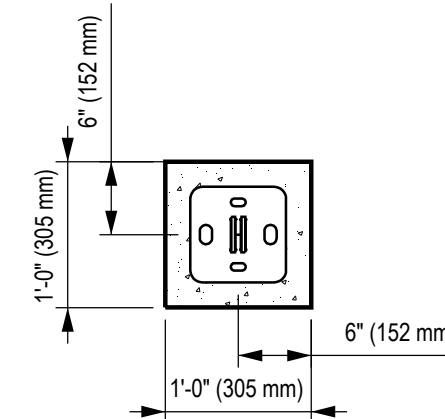

6 FT-2 DETAIL PLAN VIEW
2

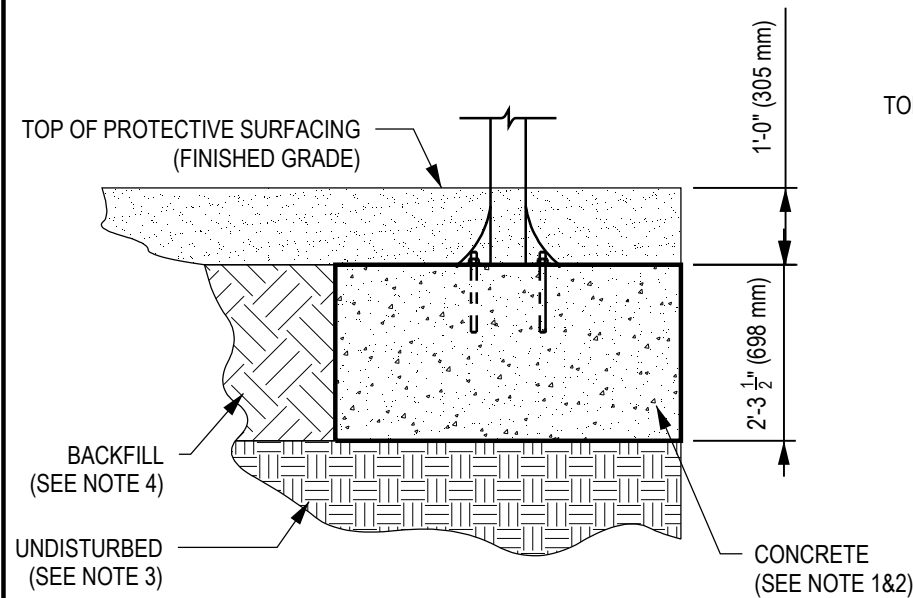

3 FT-1 DETAIL ELEVATION VIEW
2

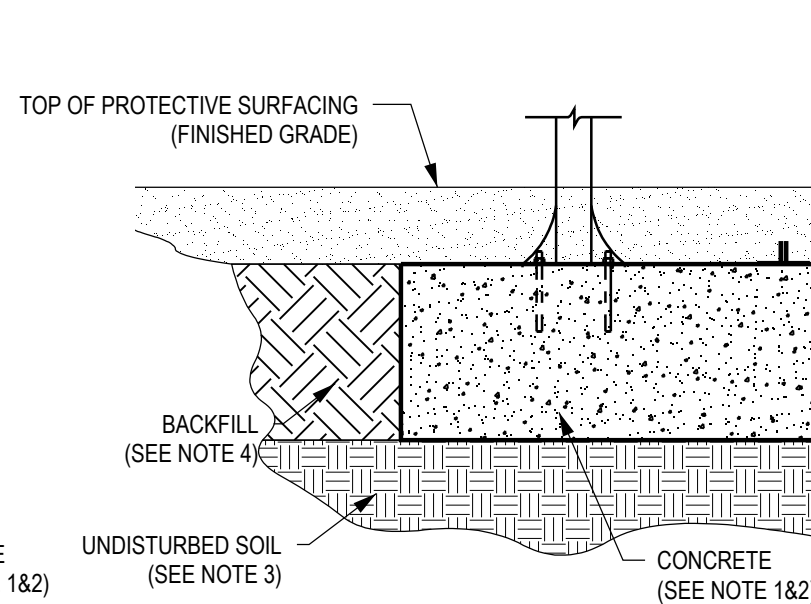

5 FT-2 DETAIL ELEVATION VIEW
2

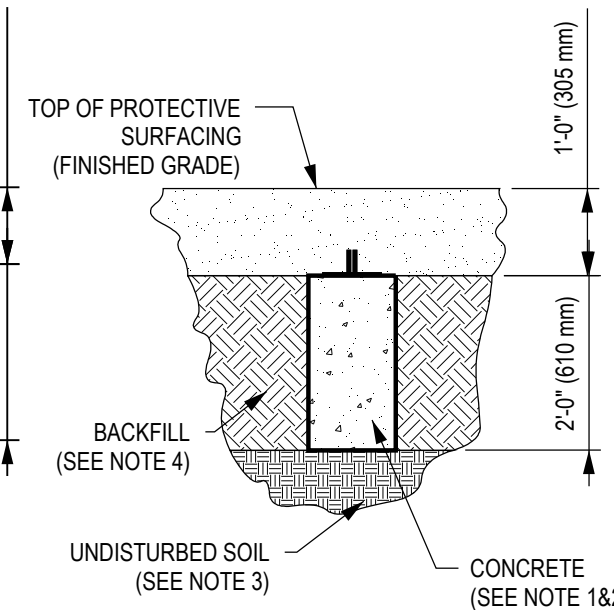

7 FT-2 DETAIL ELEVATION VIEW
2

ENGINEERING SEAL:

CLIENT: STOCK
PROJECT NAME: STOCK
PRODUCT NO: IM-1042

DRAWING TITLE:
PLAYLAND MINI FOUNDATION DRAWING

REV: 0	SHEET: 2 OF 2	SHEET SIZE: PA3	SCALE: NTS
DESIGNED BY:	DATE:		
DRAWN BY: S.ALKATHERI	DATE: 2021-07-14		
CHECKED BY: J.CHEN	DATE: 2021-08-27		
REVIEWED BY:	DATE:		
APPROVED BY:	DATE:		

DYNAMO
PLAYGROUNDS

Local: 613-446-0030
Toll free: 800-790-0034
Email: info@dynamoplaygrounds.com
Fax: 613-446-0034
URL: www.dynamoplaygrounds.com