

REVISION HISTORY				
REV	DESCRIPTION	REF. No.	DATE	DRWN BY: / RWD BY:
0	Initial Release	WO# 1912D	-	-

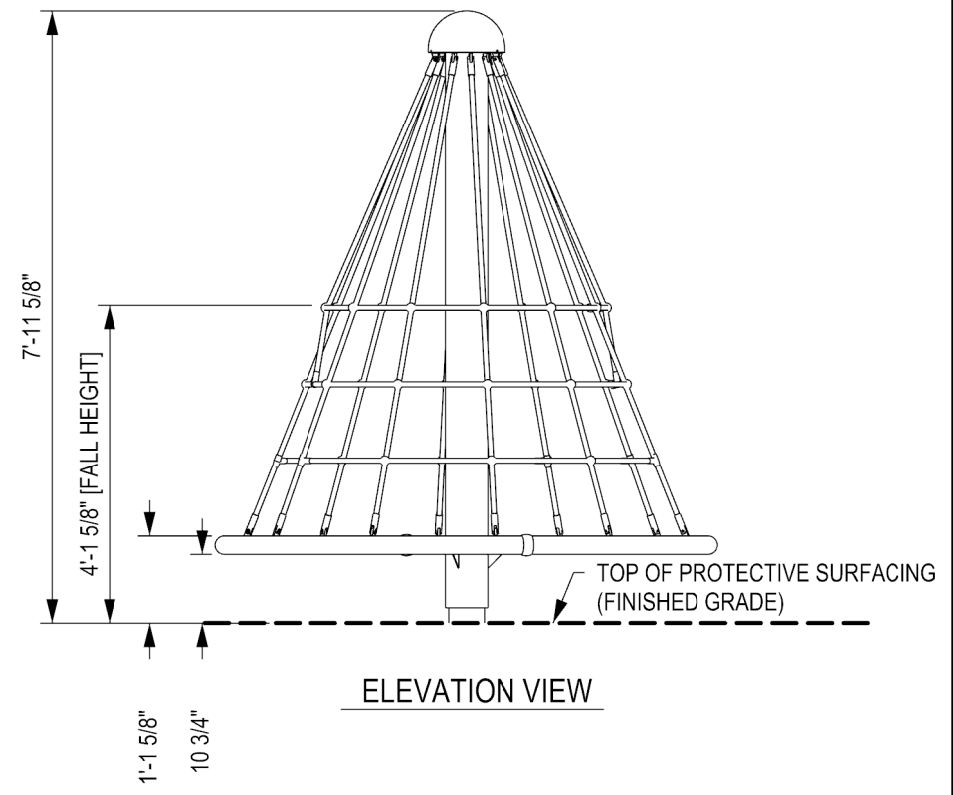
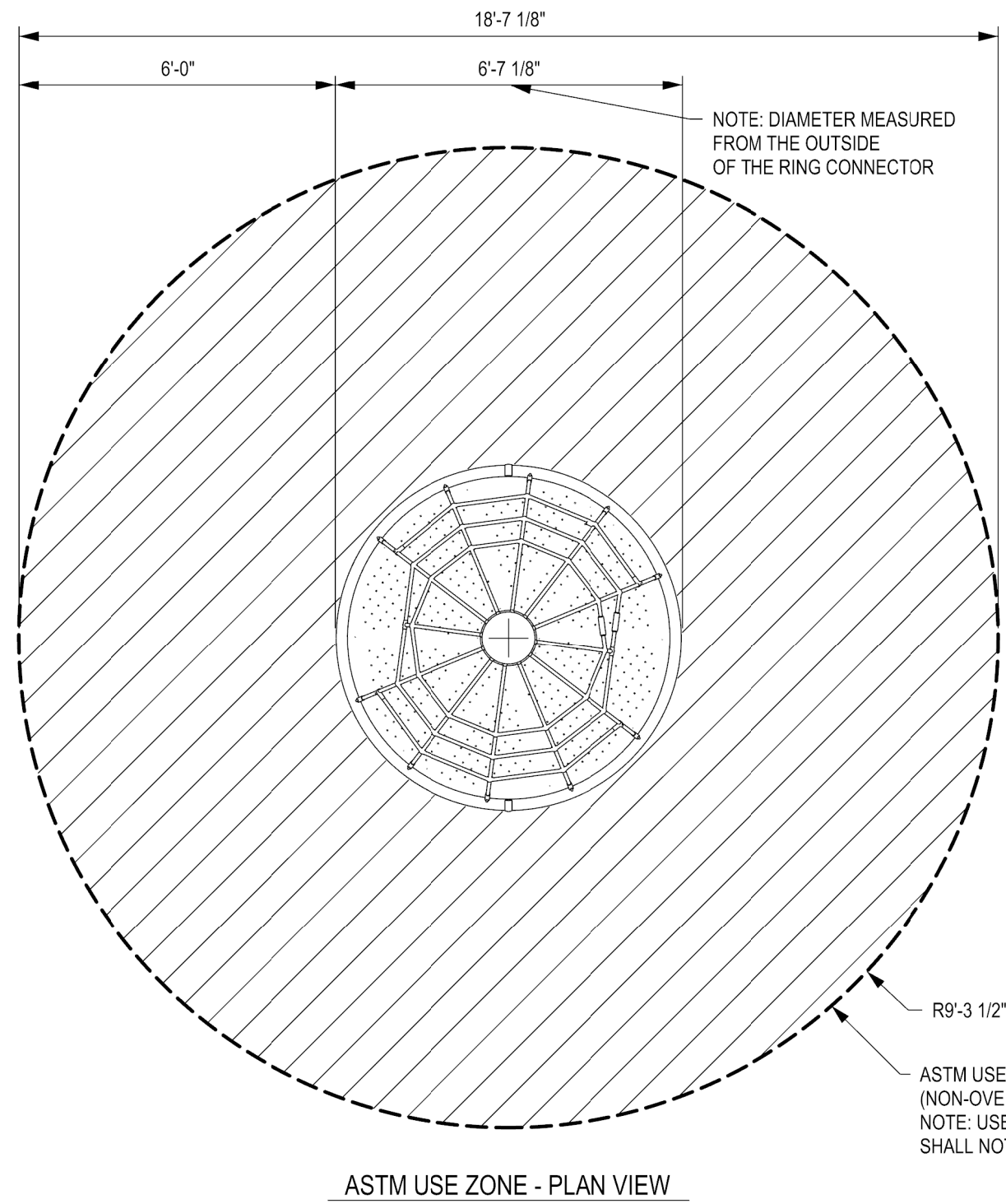

CLIENT: STOCK

PROJECT NAME: STOCK

PRODUCT NO: DX-1200

DRAWING TITLE:
**MINI APOLLO ASTM
USE ZONE DRAWING**

REV:	SHEET:	SHEET SIZE:	SCALE:
0	1 OF 1	PA3	NTS
DESIGNED BY:	W. MCNAIR	DATE:	2018-09-19
DRAWN BY:	W. MCNAIR	DATE:	2018-09-19
CHECKED BY:		DATE:	
REVIEWED BY:		DATE:	
APPROVED BY:		DATE:	

DYNAMO
PLAYGROUNDS

Local: 613-446-0030
Toll free: 800-790-0034
Email: info@dynamoplaygrounds.com
Fax: 613-446-0034
URL: www.dynamoplaygrounds.com

REVISION HISTORY					
REV	DESCRIPTION	REF. No.	DATE	DRWN BY:	RWD BY:
0	Initial Release for new design	WO# 1912D			

GENERAL NOTES:

1. THE FOUNDATION IN THE DRAWING TO BE USED AS A MINIMUM GUIDELINE. CHECK WITH LOCAL ENGINEERS
2. THE CONCRETE SHALL BE GRADE C25 (CHARACTERISTIC STRENGTH OF 3500 PSI AT 28 DAYS) MINIMUM.
3. THE FOUNDATION SHALL BE PLACED ON FIRM, UNDISTURBED SOIL SURFACE. WHEREVER EXCAVATION OCCURS BELOW THE DESIGNED FOUNDATION LEVEL, WELL COMPACTED BACK FILL OR LEAN CONCRETE SHALL BE USED FOR LEVELING.
4. BACKFILLING FOR FOUNDATION SHALL BE PLACED EVENLY IN 6" (150mm) LAYERS. LAYERS SHALL BE WELL COMPACTED.
5. THE FOUNDATION DESIGN IS SUITABLE FOR SOIL WITH A BEARING CAPACITY OF 1600 PSF (80 KPA) AND ABOVE.
6. THE FOUNDATION DESIGN IS SUITABLE FOR SOIL WITH FROST LINE OF 4' (1200 MM) OR LESS.

ENGINEERING SEAL:

CLIENT: STOCK
 PROJECT NAME: STOCK
 PRODUCT NO: DX-1200

DRAWING TITLE:
MINI APOLLO FOUNDATION DRAWING

REV: 0	SHEET: 1 OF 1	SHEET SIZE: PA3	SCALE: NTS
--------	---------------	-----------------	------------

DESIGNED BY: J. ZHAI DATE: 2017-12-19

DRAWN BY: W. MCNAIR DATE: 2018-09-20

CHECKED BY: DATE:

REVIEWED BY: DATE:

APPROVED BY: DATE:

DYNAMO
PLAYGROUNDS

Local: 613-446-0030
 Toll free: 800-790-0034
 Email: info@dynamoplaygrounds.com
 Fax: 613-446-0034
 URL: www.dynamoplaygrounds.com

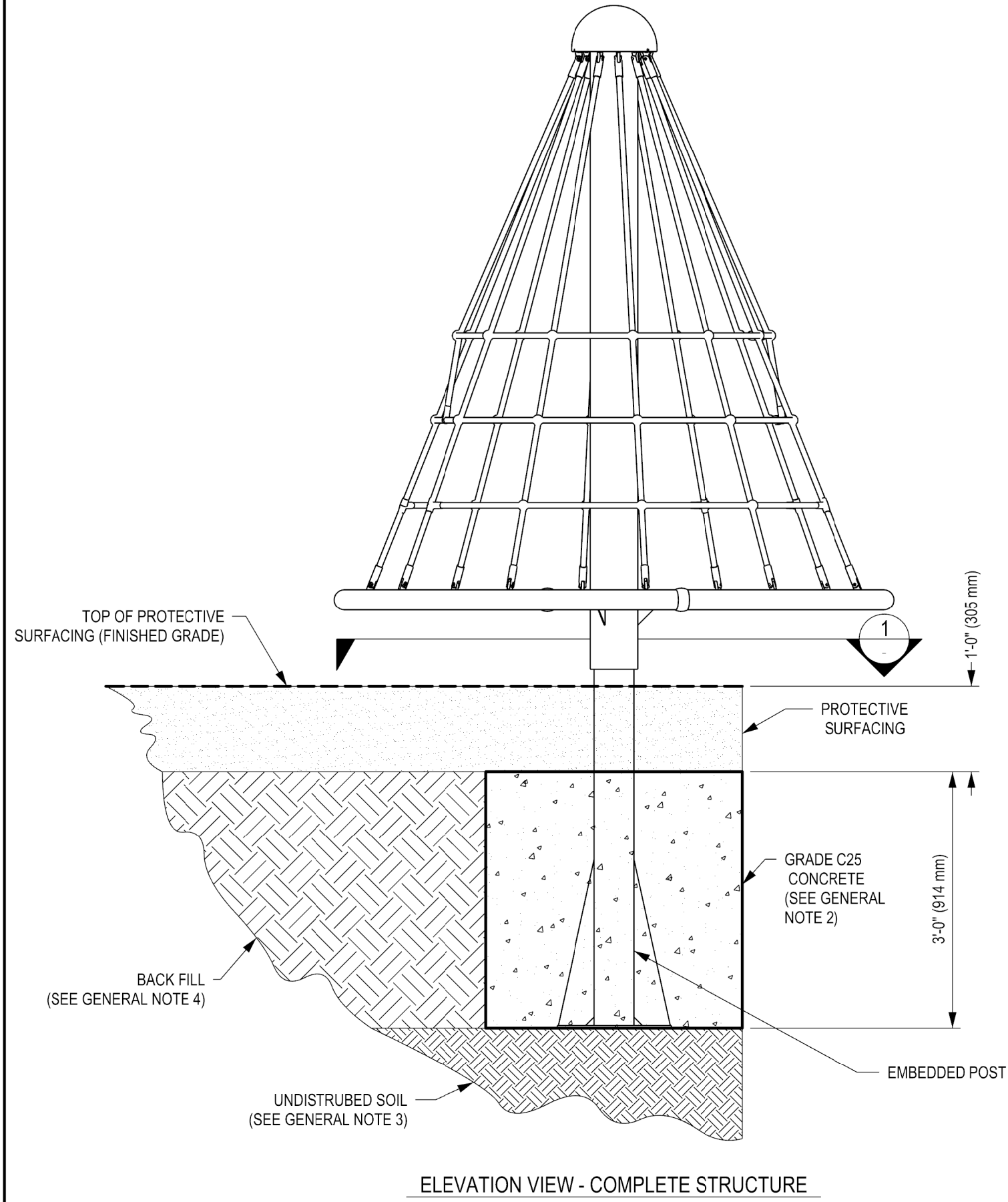

ELEVATION VIEW - COMPLETE STRUCTURE

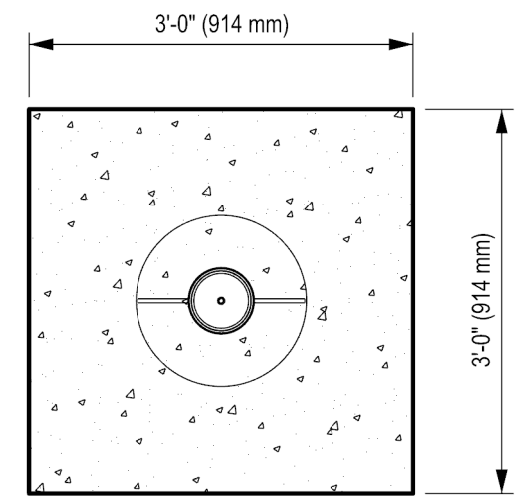

1 PLAN VIEW - POST ONLY