

This layout document provides foundation details for the preferred unitary surfacing installation. Loose fill surfacing may be an option for this product. Please inquire to determine whether this is possible prior to specifying in a project.

NOTE: PRODUCT DIMENSIONS MAY VARY.

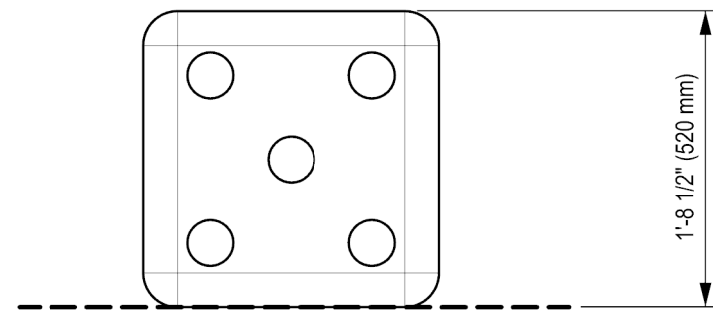

1 GIANT BLOCK ELEVATION VIEW

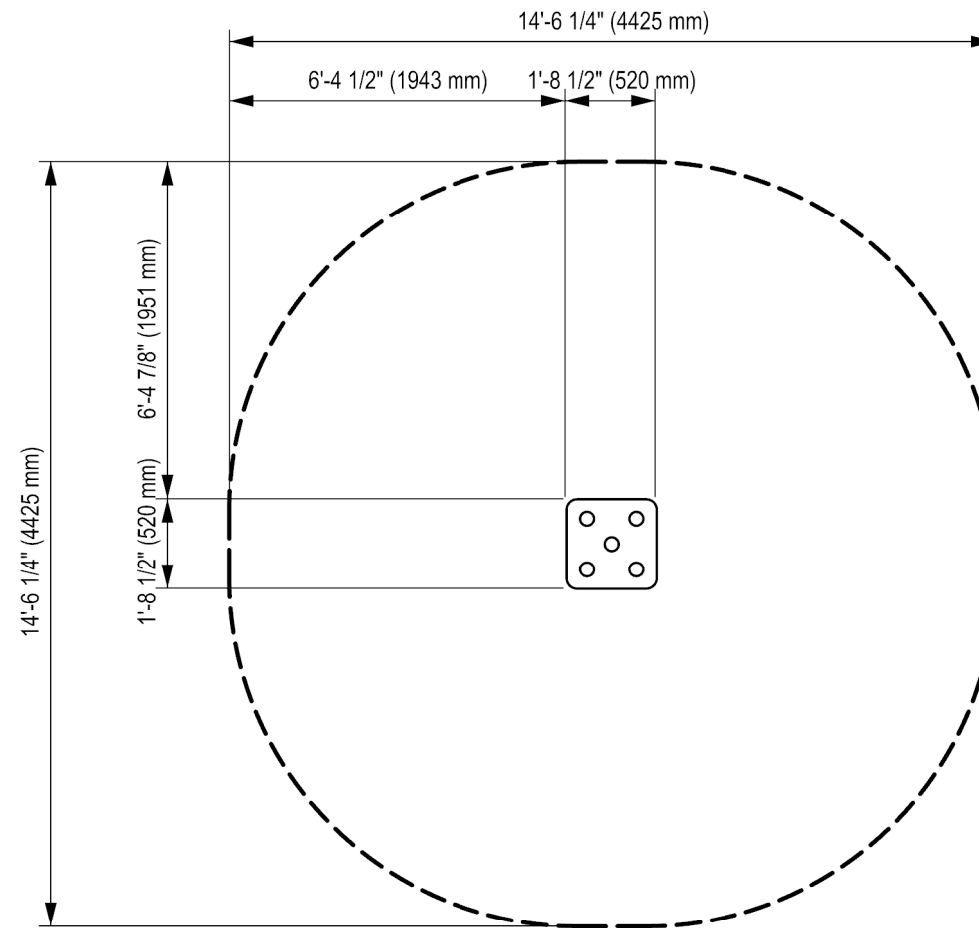

2 GIANT BLOCK CSA USE ZONE PLAN VIEW

DOCUMENT No:	200-001-162				
REVISION HISTORY					
REV	DESCRIPTION	REF. No.	DATE	DRWN BY:	RWD BY:
0	Initial Release	WO# 860	2020-11-05	CF	CF

ENGINEERING SEAL:

CLIENT: STOCK
 PROJECT NAME: STOCK
 PRODUCT NO: CPS-0047

DRAWING TITLE:
GIANT BLOCK CSA USE ZONE DRAWING

REV:	SHEET:	SHEET SIZE:	SCALE:
0	1 OF 1	PA3	NTS

DESIGNED BY:	DATE:
DRAWN BY: C. FUNG	DATE: 2020-11-05
CHECKED BY: W. MCNAIR	DATE: 2020-01-12
REVIEWED BY:	DATE:
APPROVED BY:	DATE:



Local: 613-446-0030
 Toll free: 800-790-0034
 Email: info@dynamoplaygrounds.com

This layout document provides foundation details for the preferred unitary surfacing installation. Loose fill surfacing may be an option for this product. Please inquire to determine whether this is possible prior to specifying in a project.

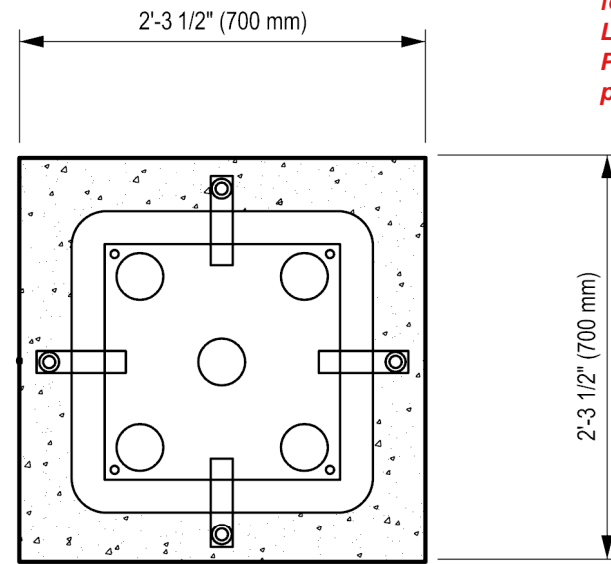

1 FOUNDATION DETAIL PLAN VIEW

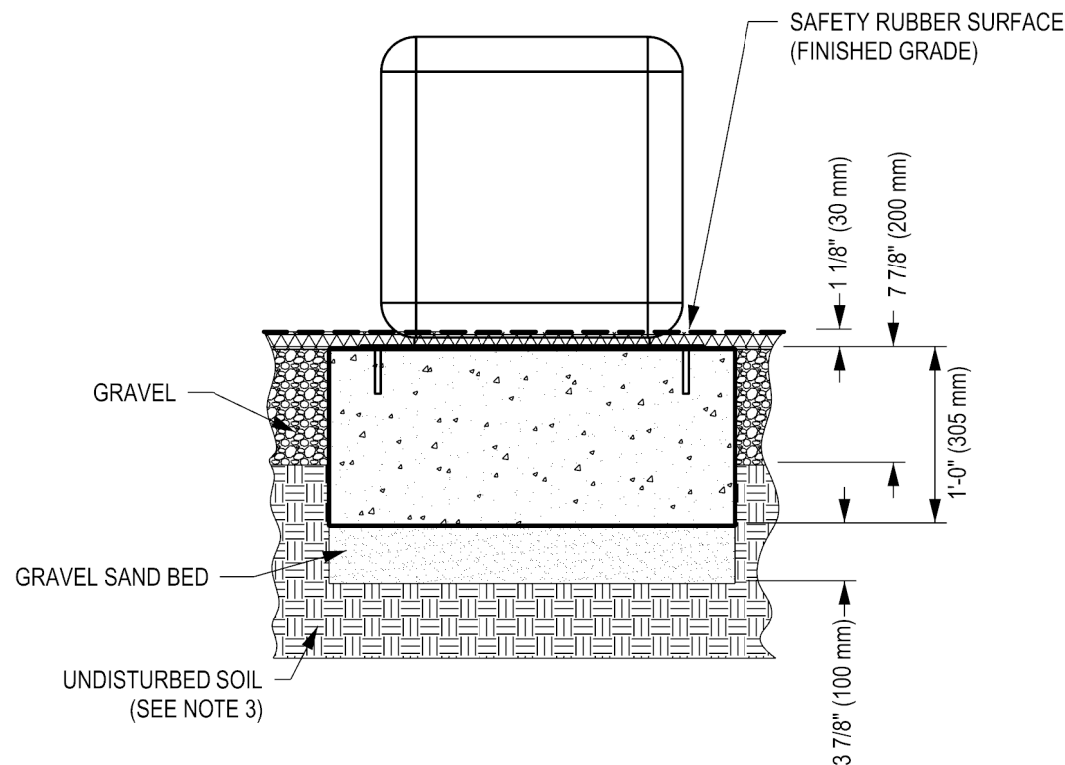

2 FOUNDATION DETAIL ELEVATION VIEW

GENERAL NOTES:

1. THE FOUNDATION IN THE DRAWING TO BE USED AS A MINIMUM GUIDELINE. CHECK WITH LOCAL ENGINEERS
2. THE CONCRETE SHALL BE GRADE C25 (CHARACTERISTIC STRENGTH OF 3500 PSI AT 28 DAYS) MINIMUM.
3. THE FOUNDATION SHALL BE PLACED ON FIRM, UNDISTURBED SOIL SURFACE. WHEREVER EXCAVATION OCCURS BELOW THE DESIGNED FOUNDATION LEVEL, WELL COMPACTED BACK FILL OR LEAN CONCRETE SHALL BE USED FOR LEVELING.
4. BACKFILLING FOR FOUNDATION SHALL BE PLACED EVENLY IN 6" (150mm) LAYERS. LAYERS SHALL BE WELL COMPACTED.

DOCUMENT No:		200-001-327			
REVISION HISTORY					
REV	DESCRIPTION	REF. No.	DATE	DRWN BY:	RWD BY:
0	Initial Release	W/O# 860	2020-11-26	CF	WM
ENGINEERING SEAL:					
CLIENT:		STOCK			
PROJECT NAME:		STOCK			
PRODUCT NO:		CPS-0047			
DRAWING TITLE: GIANT BLOCK FOUNDATION DRAWING					
REV:	SHEET:	SHEET SIZE:	SCALE:		
0	1 OF 1	PA3	NTS		
DESIGNED BY:		DATE:			
DRAWN BY:		C. FUNG		DATE: 2020-11-26	
CHECKED BY:		W. MCNAIR		DATE: 2020-01-13	
REVIEWED BY:		DATE:			
APPROVED BY:		DATE:			
 IT'S HOW WE PLAY TOGETHER Local: 613-446-0030 Toll free: 800-790-0034 Email: info@dynamoplaygrounds.com					